

# PowerTech™

## 6068HF279 Diesel Engine

Generator Drive Engine Specifications

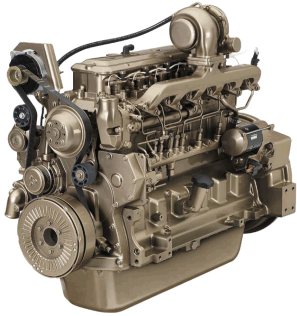

6068HF279 shown

### Engine dimensions

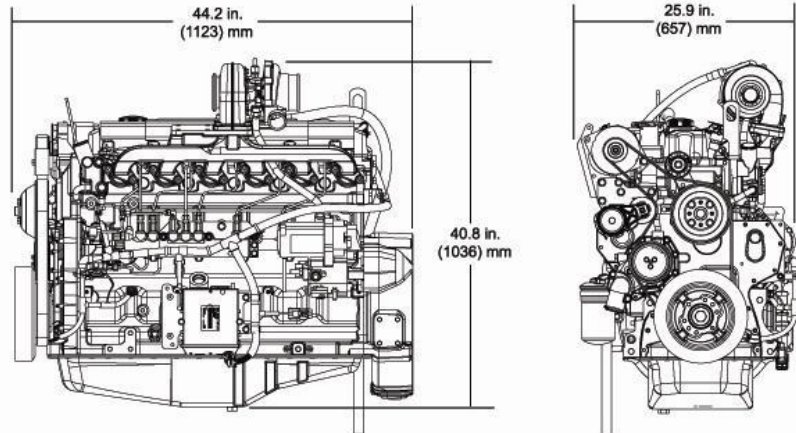

Dimensions may vary according to options selected. Call your distributor for more information.

### Emissions

EU Stage II

### General data

Model	6068HF279
Number of cylinders	6
Displacement - L (cu in)	6.8 (415)
Bore and Stroke-- mm (in)	106 x 127 (4.17 x 5.00)
Compression Ratio	19.0:1
Engine Type	In-line, 4-Cycle
Aspiration	Turbocharged and air-to-air aftercooled

Length - mm (in) to rear of block	1123 (44.2)
Width - mm (in)	657 (25.9)
Height-- mm (in)	1036 (40.8)
Weight, dry - kg (lb)	608 (1340)

### Performance data range

Rated speed Hz(rpm)	Engine power				Generator efficiency %	Rated fan power		Power factor	Calculated generator set output			
	Prime		Standby			kW	hp		Prime		Standby	
	kW	hp	kW	hp					kWe*	kVA	kWe	kVA
50(1500)	139	186	153	205	88-92	9.2	12	0.8	114-120	143-150	127-132	159-165

Prime power is the nominal power an engine is capable of delivering with a variable load for an unlimited number of hours per year. This rating conforms to ISO3046 and SAE J1995.

Standby power is the maximum engine power available at varying load factors for up to 200 hours per year when applied to conform with ISO 8528-1. This rating conforms to ISO 3046 and SAE J1995. Calculated generator set rating range for standby applications is based on minimum engine power (nominal -5 percent) to provide 100 percent meet-or-exceed performance for assembled standby generator sets.

\*Electrical power is calculated from the typical generator efficiency and fan power percentages shown. Applications may vary.

## Features and Benefits

### High Press Common Rail Fuel System

- Higher injection pressures, up to 1600 (23,500 PSI), variable injection pressure, variable timing control, multiple injections

### Dynamically Balanced Crankshaft

- Induction-hardened journals for long hours of reliable service
- Robust design to drive machinery from the front of the crankshaft
- Supported by seven main bearings

### Forged-Steel Connecting Rods

- 45-degree connecting rod/cap-joint design allows the use of large connecting rod bearings for increased durability

### Replaceable Wet-type Cylinder Liners

- Provide excellent heat dissipation
- Precision machined for long life
- Rebuild to original specifications

### Easy to Apply, Easy to Install

- Front and rear engine mounting pads on the side of the block facilitates installations
- Auxiliary drive rated to 50 hp (37 kW) intermittent for powering ancillary equipment
- Either side service for filters and service points facilitates packaging
- All connection points in common locations make it easy to install or package

### Compact Size

- Short length is ideal for both skid and packaged installations
- High mount or low mount turbocharger position to meet packaging requirements

### World-class Performance

- Excellent fuel economy and low oil consumption

### Fuel System Controls

- Self diagnostics and protection
- 12V or 24V Electric Shutoff

### Emissions

- EU Stage II