

PowerTech™ PSS 6135HFG09 Diesel Engine

Generator Drive Engine Specifications



6135HFG09 shown

Engine dimensions

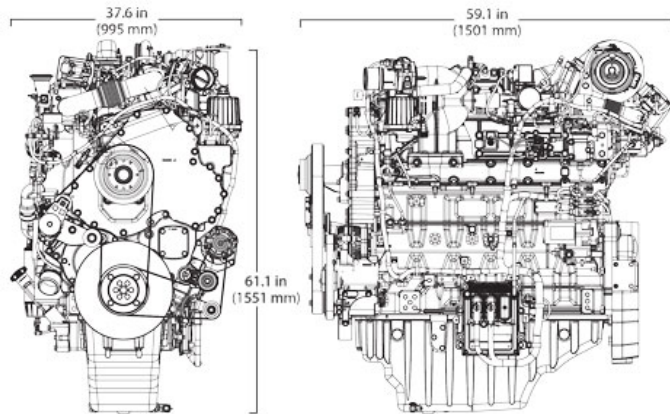

Dimensions may vary according to options selected. Call your distributor for more information.

Emissions

CARB

EPA Tier 4

General data

Model	6135HFG09	Length - mm (in) to rear of block	1501 (59.1)
Number of cylinders	6	Width - mm (in)	955 (37.6)
Displacement - L (cu in)	13.5 (824)	Height-- mm (in)	1551 (61.1)
Bore and Stroke-- mm (in)	132 x 165 (5.20 x 6.50)	Weight, dry - kg (lb)	1500 (3307)
Compression Ratio	15.3 : 1		
Engine Type	In-line, 4 Cycle		
Aspiration	Turbocharged and air-to-air aftercooled		

Performance data range

Rated speed Hz(rpm)	Engine power				Generator efficiency %	Rated fan power		Power factor	Calculated generator set output			
	Prime		Standby			kW	hp		Prime		Standby	
	kW	hp	kW	hp					kWe*	kVA	kWe	kVA
60(1800)	326-433	437-580	356-473	477-634	90-95	21.4-28.4	28.7-38.1	0.8	274-384	342-480	301-422	376-528

Prime power is the nominal power an engine is capable of delivering with a variable load for an unlimited number of hours per year. This rating conforms to ISO3046 and SAE J1995.

Standby power is the maximum engine power available at varying load factors for up to 200 hours per year when applied to conform with ISO 8528-1. This rating conforms to ISO 3046 and SAE J1995. Calculated generator set rating range for standby applications is based on minimum engine power (nominal -5 percent) to provide 100 percent meet-or-exceed performance for assembled standby generator sets.

*Electrical power is calculated from the typical generator efficiency and fan power percentages shown. Applications may vary.

DOC/DPF Dimensions

Size	7
Diameter - mm (in)	331.7 (13.1)
Length - mm (in)	838 (33.0)
Weight - kg (lb)	66.4 (146.4)

See your John Deere Power Systems engine distributor for more information on available filter size options.

SCR Catalyst Dimensions

Size	7
Diameter - mm (in)	380.8 (15.0)
Length - mm (in)	860.1 (33.9)
Weight - kg (lb)	67.5 (148.8)

Features and Benefits

Series Turbocharger

- Fresh air is first drawn into the low-pressure turbocharger (fixed geometry) and compressed to a higher pressure. The compressed air is then drawn into the high-pressure turbocharger (VGT), where the air is further compressed. The high-pressure air is then routed through a charge air cooler and into the engine's intake manifold. By splitting the work between two turbochargers, both can operate at peak efficiency and at slower rotating speeds — lowering stress on turbocharger components and improving reliability. Series turbocharging delivers more boost pressure than single turbocharger configurations which results in higher power density, improved low-speed torque, and improved high altitude operation.

Cooled Exhaust Gas Recirculation (EGR)

- EGR cools and mixes measured amounts of cooled exhaust gas with incoming fresh air to lower peak combustion temperatures, thereby reducing NOx.

Exhaust Filters

- This system is the Best Available Control Technology (BACT) for particulates that delivers premium block load acceptance characteristics and utilize a catalyzed exhaust filter that contains a diesel oxidation catalyst (DOC) and a diesel particulate filter (DPF). The DOC reacts with exhaust gases to reduce carbon monoxide, hydrocarbons, and some particulate matter (PM). The downstream DPF traps and holds the remaining PM. Trapped particles are oxidized within the DPF through a continuous cleaning process called passive regeneration. Passive regeneration occurs during normal operating conditions when heat from the exhaust stream and catalysts within the exhaust filter trigger the oxidation of the trapped PM. If passive regeneration cannot be achieved due to low temperature, load, or speed, then PM is removed using active regeneration — an automatic cleaning process controlled by the exhaust temperature management system.

Selective Catalytic Reduction (SCR)

- John Deere engines feature an SCR system that utilizes a urea-based additive, sometimes referred to as diesel exhaust fluid (DEF). The ammonia in the urea reacts with engine exhaust gases in the SCR catalyst to reduce NOx — converting it to nitrogen and water vapor.

Electronic Unit Injector (EUI) and Engine Control Unit (ECU)

- The EUI fuel system provides higher injection pressures up to 2,350 bar (34,000 psi). It also controls fuel injection timing and provides precise control for start, duration, and end of injection.

4-Valve Cylinder Head

- The 4-valve cylinder head provides excellent airflow resulting in greater low-speed torque and better transient response time by utilizing a cross-flow design.

Air-to-Air Aftercooled

- This is the most efficient method of cooling intake air to help reduce engine emissions while maintaining low-speed torque, transient response time, and peak torque. It enables an engine to meet emissions regulations with better fuel economy and the lowest installed costs.

Compact Size

- Lower installed cost
- Mounting points are the same as previous engine models

John Deere Electronic Engine Controls

- Faster engine control unit (ECU) manages both the engine and the aftertreatment
- Premium software option integrates with equipment or vehicles to reduce engineering and installation costs
- Electronic engine controls can be engine or remote mounted

Additional Features

- Gear-driven auxiliary drives and water pump
- 500-hour oil change
- Self-adjusting poly-vee fan drive
- Optional factory installed variable-speed fan drive improves fuel economy and reduces noise levels
- RH and LH engine mounted final fuel filters
- Single piece low-friction steel pistons with integrated oil cooled gallery
- Directed top-liner cooling
- Low-pressure fuel system with electrical transfer pump and "auto-prime" feature
- Optional Rear PTO